

NBAD TACKLE BOX

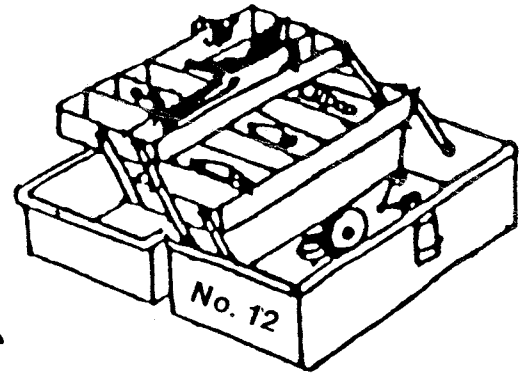

Vol. 13 No. 1

NATIONAL BASS ASSOCIATION OF THE DEAF

March 1991

Every thing is in it or it isn't Bass News

16th Annual NBAD Team Tournament Will be Held at Kentucky Lake on June 11, 12, 13, 1991 for Third Time

The 16th Annual NBAD Team Tournament will be held at Kentucky Lake at Benton, Ky. on June 11, 12, 13, 1991.

The headquarter site will be located at Sportsman's campground and marina. The tournament will be sponsored by Dayton Deaf Anglers Club with Phillip Seim as General Chairman.

It will be third time for Kentucky Lake as the tournament site since 1984.

Indiana Bass Association

of the Deaf hosted the NBAD annual team tournament at the same lake twice time in 1984 and 1987.

It will be interesting to see and find out how many of anglers participate at that lake and compare which year gets most. The first time it had 82 in 1984 and it was increased to 118 in 1987.

How many will 1991 have? We will wait and see to find out this summer. Good luck to Dayton Deaf Anglers Club.

Be Prepared to Vote the Site for 20th Anniversary Tournament

Executive Board, Charles E. Marsh, Jr., from Olathe, Ks. calls attention of all anglers and officers it is time to prepare and consider the site for our special 20th anniversary celebration of NBAD Team Tournament at Kentucky Lake this summer.

Charles believes that NBAD must keep its role as nationwide representation by having the tournament be held in nationwide site year by year. Therefore, he thinks

the 20th anniversary NBAD Team Tournament should be held at either Lake Ockeechobee, Florida or Paris Landing, Tennessee which was tabled due to voting tie.

His suggestion about having a site in either Florida or Tennessee is justified because it is time for us to realize what a title of our organization, National Bass Association of the Deaf represents. It means it stands for all 50 states of the United States.

Let's support and vote for a new and different site for the 20th anniversary event.

Do not be afraid of trying a new place or we always get in a rut!

1.

Executive Board Suggests to have Deaf Mosaic at NBAD Tournament

By Charles Marsh, Jr.

My loyalty of NBAD has been so long but I do feel that NBAD need more publicity thru television instead of only publicity of any paper publication that has been so successful. My suggestion is that I would like to contact the DEAF MOSIAC for the more picturesque activity of NBAD Team Tournament at Kentucky Lake or wait for 20th anniversary NBAD Team Tournament. I will be happy to serve the responsibilities for the possibility of having our event be filmed thru DEAF MOSIAC; therefore, I need your approval for my action.

Attention, Anglers The Reading of Minutes is No More!

At Lake Sam Rayburn, Texas, on June 10, 1990, the meeting of Council of Representatives was held and the members voted upon the motion that reading the minutes by Secretary at the meeting is not needed any more.

(Continued to page 2)

NBAD TACKLE BOX

is the official
publication of
NATIONAL BASS ASSOCIATION
OF THE DEAF

The publication is
published twice a
year in March and
September.



Founded 1976
Incorporated 1988

Founder
Robert Southwell
Past Founder
Anthony W. Mowad

1989-1990

PRESIDENT
Alan D. Rork

VICE PRESIDENT
Martin H. Miller

SECRETARY
Alice Rogers

TREASURER
Jack Stigers

PUBLICITY DIRECTOR
Joseph O. Broz

LIFETIME EXECUTIVE
Robert Southwell

EXECUTIVE BOARD
Charles E. Marsh, Jr.

Copyright 1991

Subscription rate
is \$5.00 a year.

(Continued from page 1)

In this newsletter, the minutes of Council of Representatives reads, "No read the minutes by the Secretary during the meeting, but only need to ask for any corrections or approved by all representatives."

Now, tell me how can anyone ask for any correction or approve the minutes without reading by Secretary?

Since the motion has been approved, it means that all representatives will be more responsible for keeping up knowledge or information about the minutes before attend the meeting.

You should read and memorize the minutes from our newsletter at home or bring it along to NBAD tournament.

Or you should make some copies of the minutes from newsletter before taking a trip to tournament.

Do not expect any help from officers too much about minutes!! You must be prepared well by reading the minutes in our newsletter or copies before meeting!

NBAD Urges Anglers to Consider and Vote for Western Site in 1997

A suggestion was made by Executive Board, Charles E. Marsh, Jr. that either NBAD Secretary or Publicity Director is to send out the information of opportunities of any western states region bass clubs to acknowledge their possibility of hosting 22nd or 1997 NBAD Team Tournament in their area with essential information on bidding guidelines as soon as possible.

The Publicity Director has an answer to Charles's suggestion if possible.

In 1988, at Truman Lake,
2.

in Missouri, there was close vote on bidding for 1994 Team Tournament by between Missouri and California.

Elmo Hickerson, a representative for Sacramento Valley Silent Anglers, tried and worked hard to convince the anglers that Steele Park Resort at Lake Berryessa at Winter, California was appropriate site for NBAD tournament. However, his bidding failed him and Missouri won.

The Steele Park Resort has many features; Bait & Tackle shop, Gasoline, repairs, boat rental, RV park with hook-up, swimming, grocery store, lounge restaurants, 150 campsites, motel like a walking distance, 12 inches size minimum, 5 bass limit.

Well, it would be a good idea to suggest that Sacramento Valley Silent Anglers to have an honor of being the first western bass club to host NBAD Team Tournament in 1997 without bidding at the meeting this summer if the club is willing to accept to host the 1997 event.

If there is no bidding by any western bass clubs at the meeting to sponsor the 1997 Team Tournament, then the NBAD officers will have to take over the event.

How about this suggestion?

437 Anglers Participated in Tournaments Since 1976

The National Bass Association of the Deaf was founded by Robert E. Southwell of Texas and late Anthony Mowad of Louisiana in 1976. The first Annual Individual Tournament was held at Toledo Bend Reservoir at Pendleton Bridge Marina in Louisiana. The tournament was hosted by two clubs, Texas Bass Club of the Deaf and Louisiana

Bass Club of the Deaf.

Sixty-two anglers competed in the first event and Texas sent a large group of anglers, 40, while 15 persons from Louisiana attended.

Now, the NBAD reports that there are 437 anglers who competed in NBAD's annual tournaments one time or more since an inception in 1976.

In 1987, the 12th Annual NBAD Team Tournament, hosted by Indiana Bass Association of the Deaf, had 43 rookies, the largest number, participated. Toledo Bend Reservoir received the lowest number of rookies twice, 14, in 1979 and 1985. The average number of rookies per year is about 26.

Question & Answer about Weight Slip and Individual Label

The Publicity Director recently sent out copies of questions and answers on WEIGHT SLIP, TACKLE BOX NEWSLETTER and INDIVIDUAL LABEL to 19 affiliated bass clubs.

The NBAD has received only 7 replies from the clubs.

The majority of clubs have approved and enjoyed our new TACKLE BOX newsletter.

Here is the result of the votes on weight slip and individual label as follows below:

FOR WEIGHT SLIP

No. 1 receives 5
No. 2 receives 2

FOR INDIVIDUAL LABEL

Vote for = 4
Vote against = 3

Since there are only 4 votes for individual label and the NBAD considers some clubs, which did not vote, have given their silent

consent to the project.

The NBAD has decided it will try to use it this summer for a trial.

The reason for the project is to help speed of work by officers and committee during weight process. It will reduce repetition of asking anglers for boat numbers at every time.

The officer will instantly glance at labels and put down quickly before anglers give numbers of bass and weights only.

It would not hurt us if we try on that project, and we will always find out and learn if it works or not through an experiment.

You can not prove it won't work without a tryout!

Please remember that all competitors in World Olympic games, even in Deaf Games, have to wear numbers during competition.

Individual Label

3-A

3-B

Those above labels will be attached with safety pins on back side and anglers will wear them during tournament at all times.

The numbers and letters will start with 1-A and 1-B and goes thru to 75-A and 75-B depending on how many anglers participate in tournament at that time.

The numbers represent boat numbers while the letters represent the names of anglers in alphabetical order.

The size of labels is one inch long as exact as shown above.

Weight Slip

NATIONAL BASS ASSOCIATION OF THE DEAF

1st Day, Tuesday, June 11, 1991

BOAT NO. _____

NAME _____

HOW MANY BASS _____

TOTAL WEIGHT _____ lbs.

LUNKER WEIGHT _____ lbs.

NATIONAL BASS ASSOCIATION OF THE DEAF

2nd Day, Wednesday, June 12, 1991

BOAT NO. _____

NAME _____

HOW MANY BASS _____

TOTAL WEIGHT _____ lbs.

LUNKER WEIGHT _____ lbs.

NATIONAL BASS ASSOCIATION OF THE DEAF

3rd Day, Thursday, June 13, 1991

BOAT NO. _____

NAME _____

HOW MANY BASS _____

TOTAL WEIGHT _____ lbs.

LUNKER WEIGHT _____ lbs.

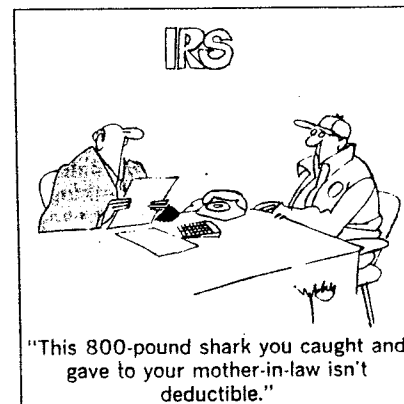

Special Cash Prizes for Setting New Records for 1991

The National Bass Association of the Deaf will award cash prize to a team or angler who breaks one of the current records. If there is no record-breaking this summer, cash prizes will be increased for next year.

Current records are listed as follows below:

LUNKER RECORD:
7 lbs. 11 oz. (1976)

BASSMASTER RECORD:
44 lbs. 14 oz. (1983)

CHAMPIONSHIP TEAM RECORD:
85 lbs. 11 oz. (1983)

Cash prizes are listed for anyone who breaks current records this summer as follows below:

**Cash Prize for New
Lunker Record
Will be \$452.00**

**Cash Prize for New
Bassmaster Record
Will be \$252.00**

**Cash Prize for New
Championship
Team Record
Will be \$252.00**

THE LOCKHORNS / By Hoest

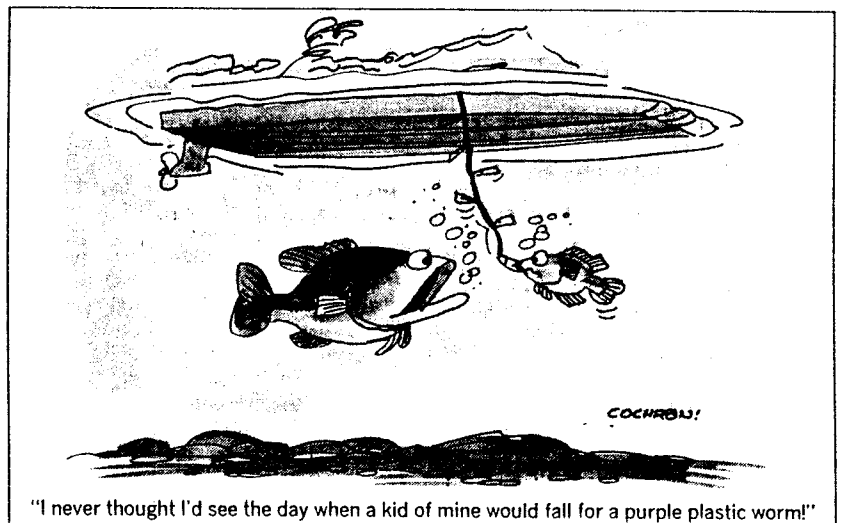
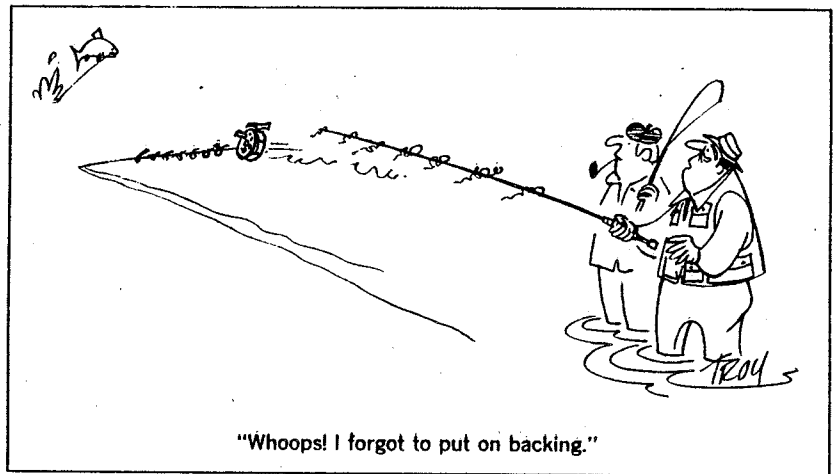
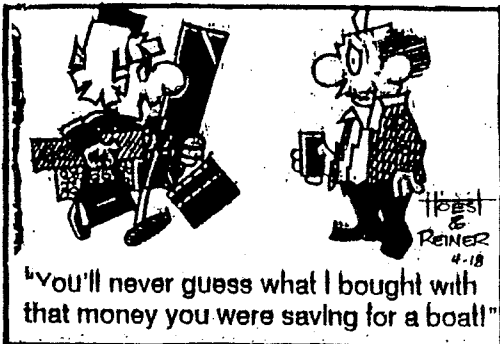

President Speaks

I would like to inform you all that our family traveled and stopped at Badlands National Park and learned about the Golden Access Passport. Since we are deaf and they gave us cards for a lifetime admission permit in the National Parks. Golden Access Passport is issued without charge to any citizen of the United States medically determined to be blind or permanently disabled for purposes of receiving benefits under federal law. It shall entitle the permittee accompanying him/her where entry is by any means other than private or noncommercial vehicle to enter any entrance fee area of the national park system administered by the National Park Service. You all deaf people go to any place of National Parks and ask for the Golden Access Passport.

NBAD received the letter from Ranger Boats Manufacturing Company that they thanked you for proposal regarding NBAD and appreciated your interesting in their company and would like to assist NBAD; however, they just can't always afford to take advantage of all the offers they receive and hope you can understand their position.

National Fraternal Society of the Deaf agrees to pay NBAD the endorser fee of 35% (one time) for the NBAD members who join NFSD. For example - a member pays a yearly premium of approximately about \$150.00. When the yearly premium is paid, NFSD send 35% (\$150.00) which would be \$52.50 to NBAD and NBAD will send 35% (\$52.50) which would be \$18.38 to local bass club. NFSD agrees to provide the lunger bass prize for \$1,000.00 to the person who breaks record. John Cloy is setting his lunger record of 7 pounds and 11 ounces. Both fishermen in a boat MUST BE NFSD members in good standing and have at least \$5,000 permanent type insurance or at least \$10,000 term insurance.

NBAD will have the present for the Hall of Fame Awards at social hour on Tuesday, June 11st at 7 P.M. after announcement of the winners for 1-2-3- places and lunger.

16th Annual NBAD Team Tournament at Kentucky Lake

Schedule of Events 1991

June 9, Sunday

- 8 A.M. NBAD Executive Board Meeting
- 1 P.M. to 5 P.M. NBAD Registration
- 7 P.M. Council of Representative Meeting

June 10, Monday

- 5 A.M. to 11 A.M. Bass Lunker Contest
- 8 A.M. to 11 A.M. NBAD Registration
- 1 P.M. General Assembly
Election of Officers
Bidding for Tournament Sites
Presentation of NBAD Patches to
Rookies
- 6 P.M. to 8 P.M. JR NBAD's Fishing Derby

June 11, Tuesday

- 5 A.M. to 3 P.M. Team Tournament
- 10 A.M. Family Recreation- Maggie's Jungle
Golf
- 3 P.M. Weigh-in
- 7 P.M. Announcement of the Winners
1-2-3 Places and Lunker
Social

June 12, Wednesday

- 5 A.M. to 3 P.M. Team Tournament
- 10 A.M. Family Recreation- New Wonder Water
- 3 P.M. Weigh-in
- 7 P.M. Announcement of the Winners
1-2-3 Places and Lunker
Door Prizes

June 13, Thursday

- 5 A.M. to 3 P.M. Team Tournament
- 1 P.M. Family Recreation- Forgotten Past
Amusement Park
- 3 P.M. Weigh-in
- 7 P.M. Announcement of the Winners
1-2-3 Places and Lunker
Announcement of Team Champions,
Sportsmanship and Bassmaster

List of Affiliated Bass Clubs and Representatives

AUSTIN BASS CLUB OF THE DEAF (A.B.C.D.)
REP: JAMES KALLINA
P.O. BOX 17501 11 MEMBERS
AUSTIN, TX. 78760

BATON ROUGE DEAF BASS ANGLERS (B.R.D.B.A.)
REP: RUDY BROWN
14305 OAK MEADOW # 48 8 MEMBERS
GONZALES, LA. 70737

BUFFALO FISHING ASSOCIATION OF THE DEAF (B.F.A.D.)
REP: WESLEY PARSONS
P.O. BOX 574 9 MEMBERS
CHEEKTOWAGO, NY. 14225

DALLAS BASS ANGLERS OF THE DEAF (D.B.A.D.)
REP: BILL COLLINS
8502 VAN PELT DR. 14 MEMBERS
DALLAS, TX. 75228

DAYTON DEAF ANGLERS CLUB (D.D.A.C.)
REP: TOM ROGERS
12167 WELLINGTON AVE. 51 MEMBERS
MEDWAY, OH. 45341

DAYTON & INDIANA DEAF ANGLERS CLUB (D.I.D.A.C.)
REP: RAYMOND RANDALL
1200 N. CIRCLE DR. 15 MEMBERS
XENIA, OH. 45385-3708

EAST TENNESSEE BASS CLUB OF THE DEAF (E.T.B.C.D.)
REP: DANNY K. COCHRAN
6442 BEAVER RIDGE RD. 18 MEMBERS
KNOXVILLE, TN. 37931

HEARING IMPAIRED BASS ANGLERS SOCIETY SY.LOUIS (H.I.B.A.S.S.)
REP: RAY Mc CLINTOCK
415 WESTBROOK DR. 8 MEMBERS
O'FALLAR, MO. 63366

HOUSTON BASS CLUB DEAF (H.B.C.D.)
REP: PATRICK STUCKEY
3620 HOLLAND DR. 12 MEMBERS
BEAUMONT, TX. 77707

INDIANA BASS ASSOCIATION OF THE DEAF (I.B.A.D.)
REP: JAMES LAIRD
117 SO. BERRY AVE. 35 MEMBERS
INDIANAPOLIS, IN. 46219

LITTLE ROCK BASS ANGLERS OF THE DEAF, INC. (L.R.B.A.D.)
REP: WILLIAM SCHWALL
P.O. BOX 46021 30 MEMBERS
LITTLE ROCK, ARK. 72214

List of Affiliated Bass Clubs and Representatives

LOUISIANA BASS ASSOCIATION OF THE DEAF (L.A.B.A.D.)
REP: ED WOOD
1339 BRIARROSE DR. 8 MEMBERS
BATON ROUGE, LA. 70810

MINNESOTA DEAF ANGLERS (M.D.A.)
REP: DAVID COLES
12113 EDGEWOOD CT. 10 MEMBERS
CHAMPLIN, MN. 55316

MISSOURI DEAF BASS ANGLERS (M.D.B.A.)
REP: MACK WILSON
10223 ST. ARSENE LN. 33 MEMBERS
ST. ANN, MO. 63074

NEW CAROLINE BASS ASSOCIATION OF THE DEAF (N.C.B.A.D.)
REP: JAMES GREENWOOD
RT. 4 BOX 337 10 MEMBERS
NEWTON, NC. 28658

OKLAHOMA BASS ANGLERS OF THE DEAF (O.B.A.D.)
REP: DONALD STANFORD
RT. # 1 BOX 74 B 8 MEMBERS
CALERA, OK. 74730

OLATHE BASS CLUB OF THE DEAF (O.B.C.D.)
REP: THOMAS EADES
12917 TRENTON 15 MEMBERS
OLATHE, KS. 66062

PORK BASS BUSTERS FOR THE DEAF (P.B.B.D.)
REP: TERRY FRISBY
6611 CROMWELL RD. 22 MEMBERS
LAKELAND, FLA. 33809

TEXAS BASS CLUB OF THE DEAF (T.B.C.D.)
REP: CARLO HOLDRIDGE
1812 BURNING TREE LN. MEMBERS
CARROLLTON, TX. 75006

WISCONSIN DEAF ANGLERS (W.D.A.)
REP: LOREN ALDERMAN
5501 REGIS DR. MEMBERS
FRIDHEY, MN. 55432

WISCONSIN DEAF SPORT CLUB (W.D.S.C.)
REP: GEORGE EVANS
ROUTE 1 BOX 68-B 5 MEMBERS
BUENEVELD, WIS. 53507



National Bass Association of the Deaf, Inc.

Founded by Robert Southwell & the Late Anthony Mowad at Toledo Bend, LA in 1976

NBAD Tournament Calendar

1989-1990

PRESIDENT

Alan D. Rork
2011 Ashbourne Road
Anderson, IN 46011
TTY 317/649-6309

VICE PRESIDENT

Martin H. Miller
56546 Hollywood Boulevard
South Bend, IN 46619
TTY 219/287-3753

SECRETARY

Alice Rogers
12167 Wellington Avenue
Medway, OH 45341
TTY 513/879-2011

TREASURER

Jack Stigers
4413 Brenda Drive
Anderson, IN 46013
TTY 317/642-5249

PUBLICITY DIRECTOR

Joseph O. Broz
P.O. Box 159
Onley, VA 23118-0159
TTY 804/787-8937

LIFETIME EXECUTIVE

Robert Southwell
Rt. 3, Box 183
Ville Platte, LA 70586
TTY 318/461-2255

EXECUTIVE BOARD

Charles E. Marsh, Jr.
1063 Ashbury Street
Olathe, KS 66061
TTY 913/782-6643

1991 TOURNAMENT GENERAL CHAIRMAN

Phil Seim
42 Estate Drive
Brookville, OH 45309
TTY 513/833-3173

1992 TOURNAMENT GENERAL CHAIRMAN

William Schwall
20 Kingsport Ct.
Little Rock, AR 72207
TTY 501/225-6415

1976 Toledo Bend, LA
1977 Toledo Bend, TX
1978 Table Rock, MO
1979 Toledo Bend, TX
1980 Lake Eufaula, AL
1981 Lake Livingston, TX
1982 Lake Eufaula, AL
1983 Lake Eufaula, OK
1984 Kentucky Lake, KY
1985 Toledo Bend, TX
1986 Bull Shoals, AR
1987 Kentucky Lake, KY
1988 Truman Lake, MO
1989 Lake Barkley, KY
1990 Sam Rayburn, TX
1991 Kentucky Lake, KY
1992 Lake Quachita, AR
1993 West Point Lake, CA
1994 Table Rock, MO
1995 NBAD
1996 Truman Lake, MO
1997 Western States Region
1998 Eastern States Region
1999 Central States Region

1992

NBAD headquarter site will be held at Mountain Harbor at Lake Quachita Resort in Arkansas. The tourney will be sponsored by Little Rock Bass Anglers of the Deaf.

General Chairman will be William O. Schwall.
His address is:
20 Kingspark Court
Little Rock, Ark. 72207

1993

NBAD headquarter site will be held at West Point Lake in Georgia. The tournament will be hosted by Indiana Bass Association of the Deaf.

General Chairman will be Winfred Larkin.
His address is:
9507 Meadowlark Drive
Indianapolis, Indiana 46236

1994

NBAD headquarter site will be held at the Indian Valeey Resort at Table Rock Reservoir in Missouri. Missouri Deaf Bass Anglers will sponsor 19th annual tournament.

General Chairman will be Edgar J. Long.
His address is:
2270 Calle Vista Drive
Florissant, Missouri 63031

1995

NBAD headquarter site will be held at either Ockeechobee Lake at Winter, Florida or Paris Landing, Tennessee.

The 20th Annual Team Tournament will be hosted by the NBAD officers.

1996

NBAD headquarter site will be held at Bucksaw Point Resort at Harry Truman Reservoir in Missouri. Wisconsin Deaf Anglers will sponsor 21st annual tournament.

General Chairman will be LeRoy D. Elmer.
His address is:
5206 Piccadilly Drive
Madison, Wisconsin 53714

1997

NBAD headquarter site will be held in Western States region.

1998

NBAD headquarter site will be held in Eastern States region.

1999

NBAD headquarter site will be held in Central States region.

Meeting of Council of Representatives

The NBAD Council of Representatives session began at the Club House at 7:40 P.M. on June 10, 1990.
Present for the meeting were as follows:

President Alan Rork
Active Vice President Medford Magill
Secretary Alice Rogers
Treasurer Jack Stigers
Publicity Director Joseph Broz
Executive Board: Robert Southwell
Charles Marsh
General Chairman Billy Buza
1991 General Chairman Phil Seim

List of Affiliated Bass Clubs

Austin Bass Club of the Deaf - Rep. James Kallina
Baton Rouge Deaf Bass Anglers - Rep. Rudy Brown
Buffalo Fishing Asso. of the Deaf - Rep. Wesley Parsons
Dallas Bass Anglers of the Deaf - Rep. Bill Collins
Dayton Deaf Anglers Club - Rep. Thomas Rogers
Dayton & Indiana Deaf Anglers Club - Rep. Ray Randall
East Tennessee Bass Club of the Deaf - Rep. Danny K. Cochran
Hearing Impaired Bass Anglers Society St. Louis -
Rep. Ray McClintock
Houston Bass Club Deaf - Rep. Patrick Stuckey
Indiana Bass Association of the Deaf - Rep. James Laird
Little Rock Bass Anglers of the Deaf - Rep. William Schwall
Louisiana Bass Association of the Deaf - Rep. Edward Wood
Minnesota Deaf Anglers - Rep. David Coles
Missouri Deaf Bass Anglers - Rep. Mack Wilson
New Carolina Bass Asso. of the Deaf - Rep. James Greenwood
Oklahoma Bass Anglers of the Deaf - Rep. Donald Stanford
Olathe Bass Club of the Deaf - Rep. Thomas Eades
Polk Bass Busters for the Deaf - Rep. Terry Frisby
Texas Bass Club of the Deaf - Rep. Carlo Holdridge
Wisconsin Deaf Anglers - Rep. Loren Alderman
Wisconsin Deaf Sport Club - Rep. George Evans

Minutes Read-Corrected-Accepted

The correction of the minute in 1997 with over 20 motel accomodations and eliminate the 2/3 majority. The minutes stand approved as corrected.

Treasurer's Report

Treasurer's financial report were audited by 2 out of states. Edward Wood (Ray Randall) accepted the auditor's committees. Passed 20-0.

General Chairman's Report

General Chairman Billy Buza provided his agenda of the events and schedules.

President's Report

President Alan Rork appointed Medford Magill as Active Vice President, because Vice President Martin Miller could not make it.

Publicity Director's Report

Joseph Broz would like to have newsletter two times a year.

Motions & Proposals

MOTION I: Olathe Bass Club of the Deaf made a proposal to N.B.A.D. that all three tournament fishing time be from 5:00 A.M. to 3:00 P.M. due to expansion of entries.

MOTION II: Dayton Deaf Anglers Club motioned that N.B.A.D. should have registration cards for only the fans at \$1.00 or \$2.00.

MOTION III: President Alan Rork move to amend the N.B.A.D. Constitution (By-Law) that 50% of quota due is sending to the daily prize and add three (3) more places. Maximum is matching the amount of money from bidding deposit by the host club. Effective will be next year.

MOTION IV: Treasurer Jack Stigers moved to amend the N.B.A.D. Constitution (By-Law) that the schedule of events is for announcement of the winners for 1-2-3 places and luncheon at 7:00 P.M. instead of 5:00 P.M. for Tuesday, Wednesday, and Thursday. Effective now.

Proposals & Suggestions

Missouri Deaf Bass Angler's proposals and suggestion for N.B.A.D. Constitution, By-Laws and Tournament Rule are:

1. Any Contestants who is disqualified and fish must not weigh.
2. No read the minutes by the Secretary during the meeting, but only need to ask for any corrections or approved by all all representatives.
3. Courage affiliated clubs of Deaf to donate NCI for fish program - Closed Captioned.
4. Local Bass Club must provide interpreter on N.B.A.D. tournament site.

General Chairman's Report

Billy Buza motioned to waive from 5 A.M. to 6 A.M. during the week of NBAD tournament. The reason is because of dark. Passed 19-0.

Unfinished Business

Mack Wilson (William Schwall) motioned to delete every 10 years to Toledo Bend and vote on any lakes. David Coles (Jerry Mikus, Sr.) close with vote. Passed. Vote on Main Motion. Passed.

Edward Wood (Mack Wilson) motioned to untabled NBAD Anniversary (20th). Vote on Edward Wood's motion. Passed 19-0.

Terry Frisby informed about Lake Ockeechobee, Florida and it has walk in distance and plenty of lodgings and good place to see.

Patrick Ferguson informed about Eufaula Reservoir in Oklahoma and explained that it has good place but the lodgings are not walk in distance.

Alan Rork informed about Paris Landing, Tenn that it has walk in distance and nice place and the complimentary will be for the officers. Thomas Eades close with vote. Passed.

Vote on Florida - 13 Oklahoma - 0 Tenn. - 13

Ronald Stanford (Thomas Eades) moved to table for next year between 2 lakes. Passed 17-0.

Alan Rork (Jerry Mikus, Sr.) motioned to untabled the three divisions. Passed. Vote on Divisions. Passed. Effective in 1997 on Western States Region.

New Business

1. Thomas Eades (Ronald Stanford) made a proposal to N.B.A.D. that all three tournament fishing time be from 5:00 A.M. to 3:00 P.M. due to expansion of entries. Robert Southwell close with vote. Passed by 2/3.

2. Thomas Rogers (Jerry Mikus, Sr.) motioned that N.B.A.D. should have registration cards for only the fans at \$1.00 or \$2.00. William Schwall (Ray Randall) amends that the \$2.00 go to Host Club. Thomas Eades close with vote. Vote on amends. Passed. Vote on Main Motion. Failed.

3. President Alan Rork (Danny K. Cochran) moved to amend the N.B.A.D. Constitution (By-Law) that 50 % of quota due is sending to the daily prize and add three (3) more places. Maximum is matching the amount of money from bidding deposit by the host club, effective will be next year. Failed.

4. Treasurer Jack Stigers (David Coles) moved to amend the N.B.A.D. Constitution (By-Law) that the schedule of events is for announcement of the winners for 1-2-3 places and lunker at 7:00 P.M. instead of 5:00 P.M. for Tuesday, Wednesday, and Thursday. Effective now. Edward Wood close with vote. Passed.

5. Mack Wilson (Wesley Parsons) motioned that any contestants who is disqualified and fish must not weigh. Passed.

6. Mack Wilson (Edward Wood) motioned that no read the minutes by the Secretary during the meeting, but only need to ask for any corrections or approved by all the reprentstatives. Passed.

7. Mack Wilson (William Schwall) motioned to courage the affiliated clubs of the Deaf to donate NCI for fish program - Closed Captioned. Ronald Stanford (Phil Seim) close with vote. Vote on Main Motion. Passed.

8. Mack Wilson (Loren Alderman) made a motion that the Local Bass Club must provide interpreter on N.B.A.D. tournament sites. Wesley Parsons (Phil Seim) close with vote. Passed.

Good order was given by Edward Wood.

Loren Alderman (Thomas Eades) adjourned at 10:35 P.M. Passed.

Meeting of General Assembly

President Alan Rork called the General Assembly session to order at 1:35 P.M. on Monday, June 11, 1990.

General Chairman's Report

Billy Buza was invited by President Alan Rork to come on the floor to inform about Pro Woman named Ann Thomason. She will give her speech about how her experience fishing.

Billy Buza explained about having derby for the children.

Vice-President's Report

Active Vice President Medford Magill gave an explanation to all Anglers about the tournament rules.

Treasurer's Report

Treasurer Jack Stigers explained about all these lunger, Sportsmanship, and Special Prizes.

Publicity Director's Report

Publicity Director Joseph Broz said he sells caps, and merchandises. He explained about History Records and Tackle Box.

Executive Board's Report

Robert Southwell wanted to explain how to establish the N.B.A.D. in 1976.

Charles Marsh explained about Bassmaster, Sportsmanship and Hall of Fame.

1991 General Chairman's Report

Phil Seim, 1991 General Chairman, informed in the process of the lodgings, marinas, launching, restaurant, and campground and informed that you all get the flyers with brochures on the table.

1992 General Chairman's Report

William Schwall, 1992 General Chairman informed that the bass club will guarantee the \$2,000 and Daily prizes of first place - \$125, second place - \$100, third place - \$75, and \$50. for lunger.

Change of Site for 1993

Jack Stigers of I.B.A.D. (Danny K. Cochran) motioned to change the lake from Moor's to West Point, Ga., because Moor's has changed the camping sites from daily rent to annually season, also only 10-15 sites for open public. Vote on Main Motion. Passed.

1996 General Chairman's Report

Leroy Elmer, 1996 Chairman of W.D.A. will have the tournament at Truman Reservoir in Missouri.

Joseph Broz, Director of N.F.D.S.R. explained about what he did work on the N.F.D.S.R.

Wesley Parsons said that he reminded his friend about NBAD sending the \$100.00 for Silent News.

Presentation of Patches to Rookies

We have 13 rookies and give them NBAD patches.

Adjourned at 3:40 P.M.

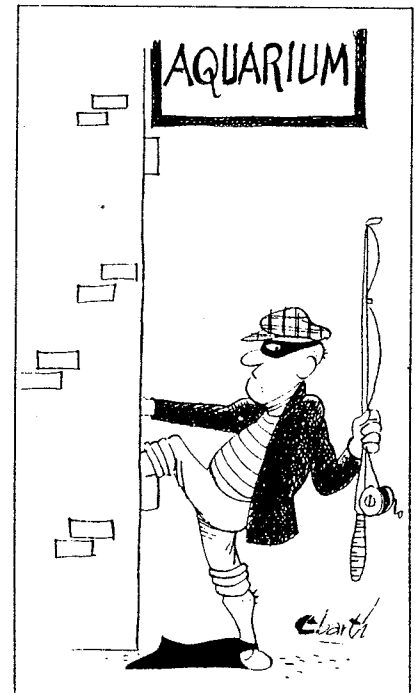
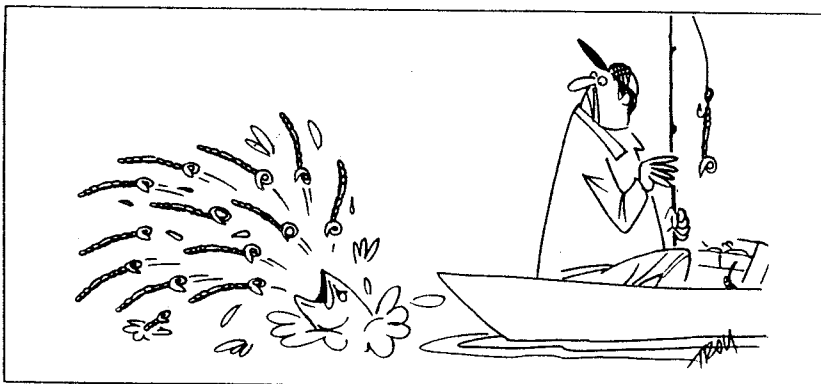
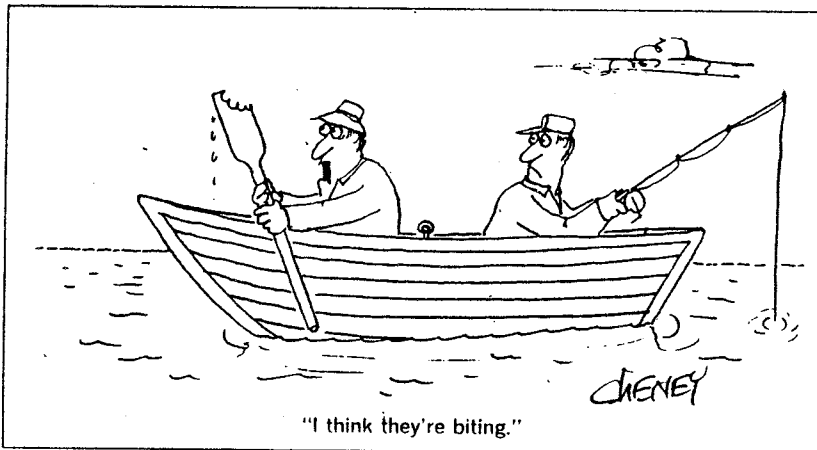

NBAD Financial Report for 1990

Financial Report of the Fifteenth Annual National Bass Association of
the Deaf Team Tournament at Rayburn Country Resort, Lake Sam Rayburn
on June 12,13,&14, 1990.

RECEIPTS

Balance brought forward	\$ 7,014.87
Affiliation Membership Dues	
20 @ \$25.00	\$ 500.00
Association Membership Dues	
14 @ \$10.00	140.00
Quota Fee 274 @ \$ 2.00	548.00
Houston Bass Club of the Deaf Deposited (1990)	270.00
Dayton Deaf Anglers Club Deposited (1991)	270.00
No-Refund Entry Fee (1989)	95.00
Donation by Edwin Slye	100.00
Interest	450.57
93 Entry Fee @ \$50.00	4,650.00
29 Late Entry Fee @ \$60.00	1,740.00
NBAD sales	230.00
TOTAL	<u>8,993.57</u>
	\$ 16,008.44

DISBURSEMENTS

1989 Minutes/Postage	\$ 200.90
Stationary/Envelopes	125.00
Incorporation Fee	10.00
Inspection Sites for 1995	168.53
Flower for John Cloy	30.00
Tackle Box Newsletter/Postage	489.94
Indiana Dept. of Revenue (1989 Tax)	38.88
Tax Service	35.00
Catch & Release Formula/BTC	225.86
NBAD Patches	654.68
2 Executive Free Entry Fees @ \$50.00	100.00
1 Free Entry Fee - Gene Amons	40.00
NBAD Video Tapes	50.73
NBAD Blackboard	106.47
NBAD Luncheon	43.75
Billy Buza s Transportation	13.00
Daily Prizes	600.00
Prize Fees	4,270.00
H.B.C.D. Host	610.00
Bassmaster Prize	122.00
Lunker Prize	122.00
Indiana Bass Assn of the Deaf (NFSD Commission)	27.80
Bassmaster/Sportsmanship Trophies	70.00
Service Charge	5.00
Officers Expense;	
Alan Rork, President	127.16
Martin Miller, Vice-President	86.37
Alice Rogers, Secretary	18.47
Jack Stigers, Treasurer	27.66
Joseph Broz, Pubicity Director	157.47
TOTAL	<u>\$ 8,576.67</u>

RECAPITULATION

Receipts total	\$ 16,008.44
Disbursement total	<u>8,576.67</u>
Net Balance	\$ 7,431.77

FUNDS

NBAD General Fund	\$ 2,077.77
Dayton Deaf Anglers Club (1991)	600.00
Little Rock Bass Anglers of the Deaf (1992)	330.00
Indiana Bass Association of the Deaf (1993)	600.00
Missouri Bass Deaf Anglers (1994)	600.00
NBAD Annual Fund (1995)	548.00
Wisconsin Deaf Anglers (1996)	1,500.00
Lunker Record (7 lbs & 11 oz)	452.00
Bassmaster Record (44 lbs & 14 oz)	252.00
Team Champion Record (85 lbs & 14 oz)	252.00
3 Entry Fees	120.00
2 Executive Entry Fees	100.00
TOTAL	<u>\$ 7,431.77</u>

Submitted by Jack Stigers, Treasurer.

BASS CLUB NEWS

FLORIDA

POLK BASS BUSTERS FOR THE DEAF

By David Lang,
Newsletter Editor

As the Central Florida Area grows by leaps and bounds, also the Bass Busters grows by membership and pounds and ounces.

This year, 1991, will be our fifth for providing tournaments for the hearing impaired community of Central Florida. A total nine bass tournaments were sponsored for a total of 91 fisherspersons. Yes, we have some lucky ladies fishing with us. We also mailed newsletters to approximately 70+ people.

A special cash awards was established this year for the lucky angler who beats Terry Frisby's record of 7.18 pounds. So far no one has topped that.

Highlight of the year was our fourth bass classic and dinner. Eight anglers fished that day and 48 attended a dinner in Winter Haven. A super time was had by all.

This tournament and dinner continues to grow!

Two of our basses journeyed in June, 1990, to Lake Sam Rayburn in Texas. Although they did not win any prizes, they had a very good time. Lester Smith caught 1.46 pounds and Terry Frisby caught 1.32 pounds. Individually Lester Smith was at 80th and Terry Frisby was at 85th.

In closing, we again invite all deaf basses to come and join us in fishing in Central Florida's many beautiful and productive lakes.

Thank you.

KANSAS

EADES WINS AWARD FROM BASS CLUB OF THE DEAF

By Charles Marsh, Jr.

Thomas Eades won the top award for 1990 at the Olathe Bass Club of the Deaf's 14th annual banquet on Nov. 7 at Pizza Shoppe.

Eades caught 22 pounds, 11 ounces for the year. Eades had five keepers for the year, the most by a club member. Charles Marsh was in second place with 21 lbs. 3 oz. Marsh was also selected as Most Improved Angler.

Ronald Motes had the Lunker of the Year, a 5 lb. 2 oz catch.

Larry and Wayne Neill won a special award for their fund-raising effort for the club over the past three years.

Election of officers for 1991 will be held during the December meeting.

1990 OLATHE BASS CLUB OF THE DEAF YEAR-END STANDINGS

1. 22 lbs. 11 oz. - Thomas Eades
2. 21 lbs. 3 oz. - Charles Marsh
3. 17 lbs. 13 oz. - Kevin Meyers
4. 17 lbs. 2 oz. - Ronald Motes
5. 11 lbs. 7 oz. - Wayne Neill

BASS CLUB ELECTS NEW OFFICERS

By Charles Marsh, Jr.

Four of the five officers of the Olathe Bass Club of the Deaf were re-elected for 1991.

The new officers elected was Jeff Willoughby as tournament director. The re-elected officers are:

PRESIDENT -

Larry Neill

VICE-PRESIDENT -

Ronald Motes

SECRETARY -

Charles E. Marsh, Jr.

TREASURER -

Doug Mullins

Neill appointed Willoughby, Thomas Eades and Chuck Theel to a law committee to revise the club's by-laws and tournament guidelines.

Next month the members will select the lakes for the tournaments from March thru October. In February, the club will have a swap-or-sale.

NORTH CAROLINA

DISMAL SEASON FOR N.C.B.A.D.

By Randolph Poteat

The North Carolina Bass Anglers of the Deaf have completed their worst year of all times. It is hard to believe that we only had 9 full members of 1990. Why? What is going on? What made a healthy fishing club of 30 members slowly dwindle down to just 9 full members?

I will attempt here to explain the mystery here. Not all reasons can be explained. Various reasons. They include Billy Bledsoe, Albert Woodel and Tim Saunders.

Richard Lockamy and Gene Smith often find they have to work on tournament days.

They both work for newspapers.

We even had 2 people who cannot stand staying under the sun on hot days.

BASS CLUB NEWS

Of course age takes a toll on some of us.

Some, around 5 members have stopped fishing with us because of driving great distances to tournaments. Remember that N.C. has only one bass club. Members are spread out in the state of N.C. from the beaches to the mountains. We try to balance our tournaments evenly between the East and West on ten different lakes. As you can imagine, some of us enter "hearing" tournaments near their homes while ignoring N.C.B.A.D. tournaments 300 miles away. We can not really blame these people.

We even had one man, ordered by his doctor not to fish any more. He suffered an accident on a railroad crossing. His back is very sensitive to sudden movements.

There are still some who have stopped fishing without notice and without reason.

I have tried to explain to the best of the club's knowledge why we are shrinking. That should not cloud our future because we have some new faces coming aboard.

We have Steve Morris, who recently moved back to N.C. after living in Atlanta for more than 5 years. We have Ken Phillips who even bought a nice bass boat. Rumors are flying that he might move to Michigan with his newly wed wife. Earl Smith also joins us. He has a nice fishing boat and knows a lot of crappie holes on Lake Jordan. We welcome all of you!

Our club at present doesn't have an associate membership list like some clubs do.

There are some southern clubs that has an associate membership over 100! However, their full membership have very low numbers, not much

more than the N.C.B.A.D. membership now.

After the Gulf war is over we hope to lure more members to our proud club.

FREAK ACCIDENT KILLS CARL DUPREE

By Randolph Poteat

Earlier this fall the Deaf Bassing world was shocked by a strange death on the campus of Gallaudet University in Washington, D.C. It seems that Gallaudet Security police were in the process of putting handcuffs on sophomore student Carl Dupree when he choked to death. It is not really known by this writer how it really happened. It is considered a wrongful death or homicide and it is still under investigation.

It is rumored that Carl's wife is bringing a lawsuit against Gallaudet Security. It was a real shame that it had to happen.

For those who don't know Carl Dupree, 41 years old, he was a former guide on Lake Eufaula in Alabama and was a close friend of Tom Mann. He was also president of Southern Bass Association of the Deaf during 1987-88.

He led an extraordinary life. Being a deaf professional guide on Lake Eufaula is almost impossible, yet he did. His help and expertise helped many of us. He will greatly be missed by all of us.

KOONCE LANDS BASS ANGLER AWARD

By Randolph Poteat

The N.C.B.A.D. tournament trail ended with 2 straight cancellations due to high winds, and freezing rain.

That left us with just 7 completed tournaments, not counting our "Classic". So it's highly unlikely that on one man could dominate the whole season. However, Cecil Koonce won 4 out of 7 tournaments and came in 2nd place once. And once he caught nothing but against all odds, he still made it look so easy catching over 32 pounds of fish while second place Jesse Church had almost 17 pounds. Coming in at third place was Roger Stewart. 4th place was owned by Johnny Barnes while 5th place was for Gary Greenwood. Taking up 6th place was Randy Poteat while 7th place belonged to Darrell Yates. James Jackson had 8th place, followed by Mack Morrison and Bob Page. Mike Branch fishing just once took the final spot at 10th place.

It was the first time that we have had any cancellations since 15 years. Normally, we don't have a cancellation policy, regardless of the weather but when too few show up at a tournament site, they can decide to forgo the tourney. That happened to us twice this year. It is most unusual!

We have to congratulate Cecil Koonce on a most successful season. Well Cecil, we hope you are enjoying your season now because next year will be a different season. Right, guys?

POTEAT "RETIRES" BOAT

By Randolph Poteat

A familiar sight will be missing at N.B.A.D., Southern Bass Association of the Deaf, N.C.B.A.D. and hearing bass tournaments as Randy Poteat has finally retired his bass boat after 19 years

BASS CLUB NEWS

of hard fishing. His boat, built in 1972, has a 65 h.p. Mercury, is green with tiny black dots but it is getting too old and dangerous to compete with today's modern bass boats. His boat has been involved in over 210 tournaments since 1972. He has taken it out numerous times for pleasure fishing.

So common sense tells you that it is time to stop using it for serious fishing.

After repairs, he will only use it for family outings.

Many fond and sad memories are forever remembered from this boat. It was used in 7 N.B.A.D. and 5 S.B.A.D. tournaments. He has not really had much mechanical problems but had to repair holes in the boat often. The boat was never parked under a roof since 1972, so you can imagine the damage the weather has inflicted. The boat has a lot of mileage on it. For example, in the last 2 NBAD tournies Randy and his partner, Steve Morris, drove 40 miles or more everyday at Lake Barkley and Sam Rayburn.

Randy has a bad habit of fishing far from other competitors, as you well know.

Randy is most proud of his live well. He has seen it holds many bass and still live while most modern bass can't compare. Very recently he and Steve Morris caught over 50 catfish weighing over 1½ pounds each and they all survived overnight while the boat was out of the water.

The boat has really accomplished a lot during its 19 year history on the tournament trail. Lately it has been the smallest, slowest and oldest boat in all its tournaments. It is time for Randy Poteat to find a more suitable boat for today's tournies.

If there is ever a boat Hall of Fame, Randy's green boat should have a place there. It already occupies a place in many hearts who have fished with him.

Farewell, Green Ghost.

1991 OFFICERS FOR NORTH CAROLINA BASS ANGLERS OF THE DEAF

North Carolina Bass Anglers of the Deaf elected new officers for 1991. The elected officers are:

PRESIDENT -

Roger Stewart

VICE-PRESIDENT -

Johnny T. Barnes

SECRETARY -

Randy Poteat

TREASURER -

Jesse Church

REPRESENTATIVE FOR NBAD -

James G. Greenwood

TENNESSEE

BASS CLUB ELECTS NEW OFFICERS

East Tennessee Bass Club of the Deaf elected officers for 1991.

Here is a result of election of officers as follows below:

PRESIDENT -

Danny K. Cochran

VICE-PRESIDENT -

Phil Huckaby

SECRETARY -

Roy Blaylock, Jr.

TREASURER -

Ron Ogle

The East Tennessee Bass Club of the Deaf will have annual tournament on Sept. 7 and 8, 1991.

MISSOURI

Missouri Deaf Bass Anglers elected new officers for 1991. The result of election of officers is as follows below:

PRESIDENT -

Dale Wentz

VICE-PRESIDENT -

Aaron Lange

SECRETARY -

Virginia Long

TREASURER -

Bobby Eakins

MEMBER AT LARGE

Mack Wilson

Barry Santens

Barbara Lange

NBAD REPRESENTATIVE

Mack Wilson

ALTERNATE REPRESENTATIVE

Aaron Lange

The Missouri Deaf Bass Anglers has already planned tournament schedule for 1991.

Here is a list of dates and places as follows below:

MARCH 9-10 - Wappappello

Lake at Chonia's Landing

APRIL 6-7 - Pomme De Terre

at Nemo marina

APRIL 27 - Table Rock Lake

at Port of Kimberling

(Special Buddy Tournament)

MAY 8 - Lake of Ozarks

at Tonka marina

JULY 6 - Truman Lake

(Missouri vs. Kansas)

JULY 21 - Mark Twain Lake

at The Landing marina

AUG. 3-4 - Lake of Ozarks

at Grand Glaize Beach

State Park

SEPT 14 - Wappappello Lake

at Chonia's Landing

SEPT 28 - Mark Twain Lake

at The Landing marina

(Classic Tournament)

All Time Tournament Records

(for 1990)

LARGEST ATTENDANCE - 128 - 1989 - Lake Barkley, Kentucky
LOWEST ATTENDANCE - 56 - 1982 - Lake Eufaula, Alabama
LOWEST ATTENDANCE - 56 - 1983 - Lake Eufaula, Oklahoma
LARGEST NUMBER OF ROOKIES - 43 - 1987 - Kentucky Lake, Kentucky
LOWEST NUMBER OF ROOKIES - 14 - 1979 - Toledo Bend Reservoir, Texas
LOWEST NUMBER OF ROOKIES - 14 - 1985 - Toledo Bend Reservoir, Texas
MOST ENTRANTS FROM STATE - 41 - Texas - 1977 - Toledo Bend Reservoir, Texas
MOST PARTICIPANT SINCE 1976 (15 Years) - Medford Magill, Charles Marsh & Jerry Mikus
MOST HOST OF TOURNAMENT - 3 times by Olathe Bass Club of the Deaf
MOST TOURNAMENT SITE - 4 times at Toledo Bend Reservoir
TOTAL PARTICIPANTS COMPETED SINCE 1976 - 437
MOST STATE LEADING CHAMPIONSHIP TEAM - 6 times by Louisiana
MOST CHAMPIONSHIP WINNER - 5 times by Harry Trahan, Louisiana
MOST BASSMASTER AWARD WINNER - 3 times by Gene Amons, Louisiana
LARGEST LUNKER - 7 lbs. 11 oz. - 1976 - John Cloy, Louisiana (deceased)
MOST LUNKER CHAMPIONSHIP WINNER - 2 times by Harry Trahan, La.
MOST LUNKER WINNER OF THE DAY - 3 times by Abel Garcia, Tx. & Karl Nygaard, Wi.
HEAVIEST TEAM (1 day) - 35 lbs. 14 oz. - 1983 - Gene Amons & Harry Trahan
TOTAL HEAVIEST TEAM (3 days) - 85 lbs. 14 oz. - 1983 - Gene Amons & Harry Trahan
HEAVIEST INDIVIDUAL (1 day) - 20 lbs. 0 oz. - 1983 - Gene Amons
TOTAL HEAVIEST INDIVIDUAL (3 days) - 44 lbs. 14 oz. - 1983 - Gene Amons
MOST INDIVIDUAL CATCH OF 10 LBS. & OVER IN 3 DAYS - 9 times by Gene Amons
MOST INDIVIDUAL CATCH OF 10 LBS. & OVER IN ONE DAY - 5 times by Gene Amons



PRACTICE NOT TO TOSS IT AWAY!!!

TRUMAN LAKE

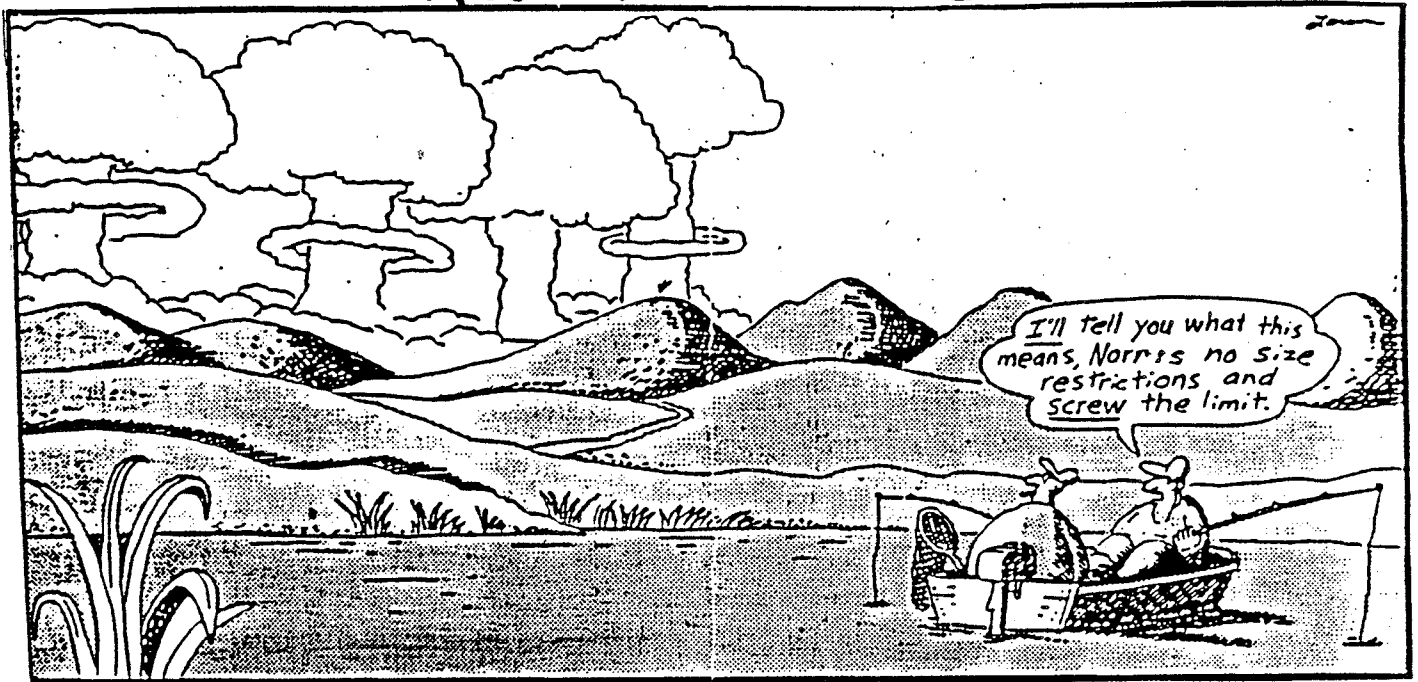

THE LOCKHORNS / BY HOEST

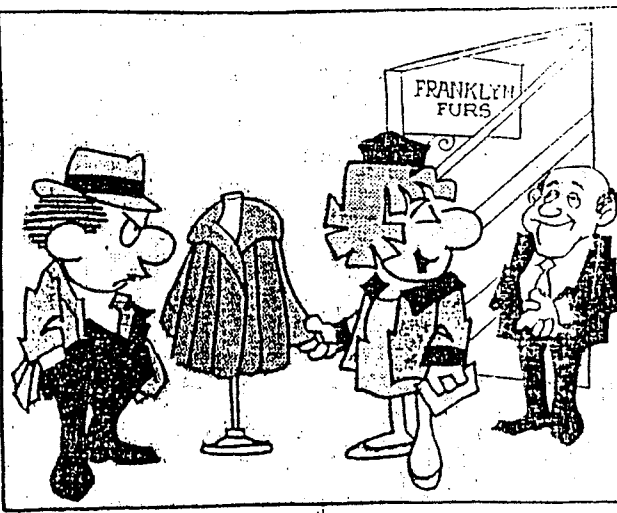

"DO YOU HAVE SOMETHING ABOUT THE SAME PRICE AS A BASS-FISHING BOAT INCLUDING THE TRAILER?"

ER SNICKERS

BY BILL HOEST

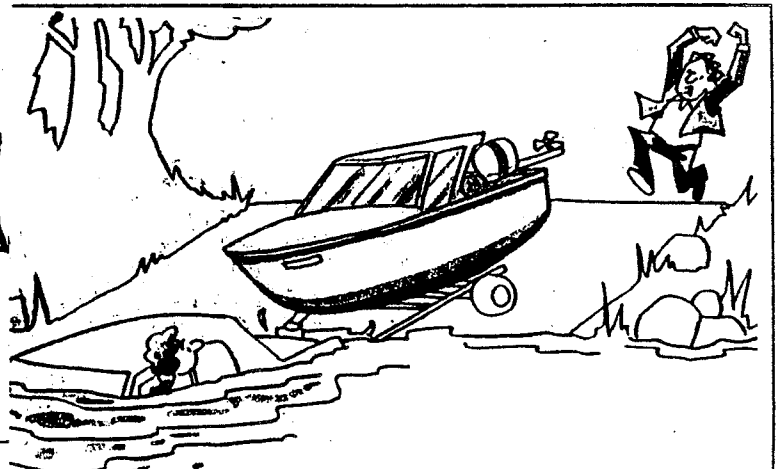

"No, no! You're supposed to BACK it in!"

U. ENQUIRER

SHOE / By Jeff MacNelly

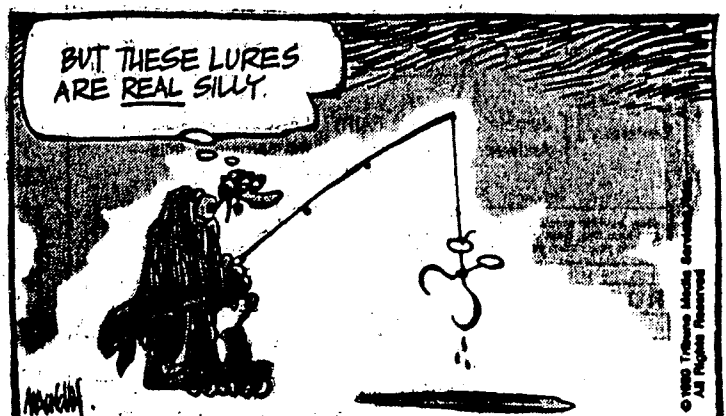



A. NBAD cap (red & white)



B. NBAD decal (8 1/4" x 7 1/4")
(red, blue, white with green bass)

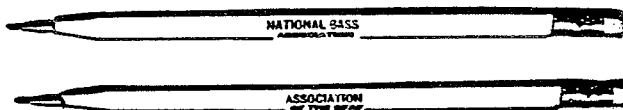

C. NBAD pen (Color: ivory)



D. NBAD patch (3-7/8" x 3")
(red, blue, white with green bass, better quality)



E. 10 oz.
CATCH and RELEASE

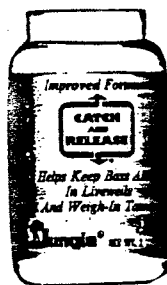

F. 2 oz.
CATCH and RELEASE

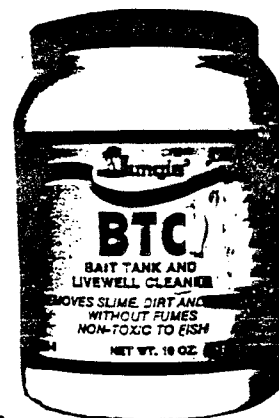

G. 10 oz. BTC

NBAD ORDER FORM

TO:
Joseph O. Broz, Publicity Director
P.O. Box 159
Onley, Virginia 23418-0159

FROM:
NAME (Print clearly) _____
ADDRESS _____

Enclosed is my check/money order for \$ _____ for the items marked below.

<u>QUANTITY</u>	<u>ITEM</u>	<u>QUANTITY</u>	<u>ITEM</u>
_____	A. NBAD cap \$6.00	_____	E. 10 oz. CATCH and RELEASE .. \$5.00
_____	B. NBAD decal 5.00	_____	F. 2 oz. CATCH and RELEASE .. 2.00
_____	C. NBAD pen25¢ each	_____	G. 10 oz. BTC 4.00
_____	D. NBAD patch 4.00		



16th ANNUAL National Bass Association of the Deaf Team Tournament June 11, 12, 13, 1991

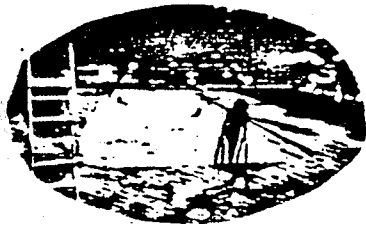

Sponsored By

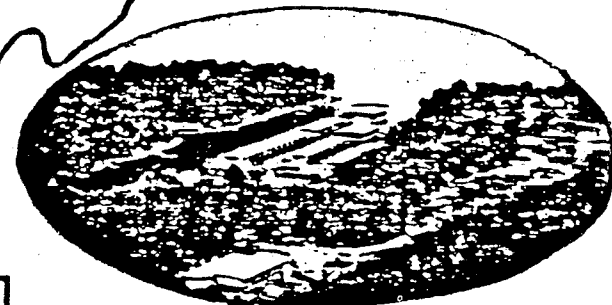
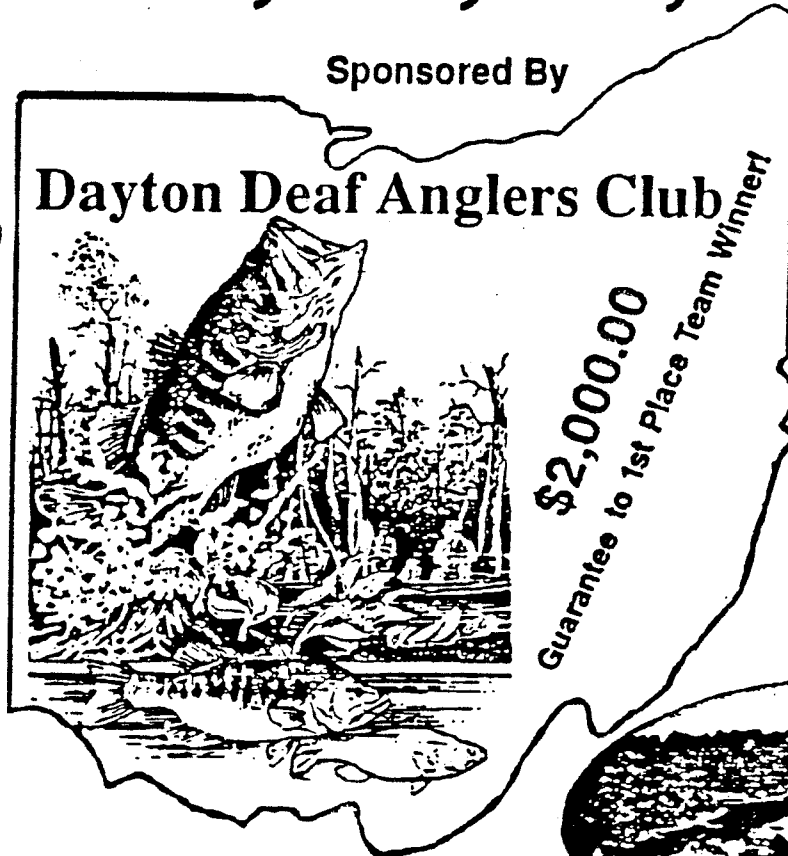

For Information Write To:
General Chairman Phil Seim
42 Estate Drive
Brookville, Ohio 45309
TTY (513) 833-3173

Sportsman's
Campground
&
Marina

Route 5, Box 401, Hwy. 68
Benton, Kentucky 42025
For Reservations call (502) 354-8333
Marina (502) 354-6568
Campground (502) 354-8493

Sportsman's Lodge

Hwy 68 at Jonathan Creek

Rt 5 Benton 42025

(502) 354-8333

1-800-553-6716

Motel units, sleeper cottages with or without kitchen, large cottages, efficiency apartments and mobile homes. Swimming pool, volleyball, tennis, shuffleboard, and picnic area.

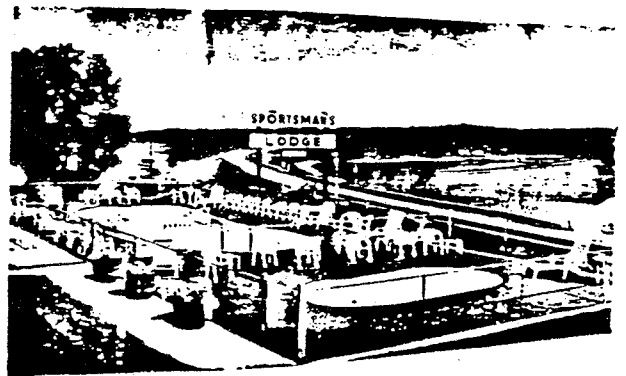

All occupancy rates are daily rates for the number of persons stated or fewer. There is a \$5.00 per day charge for each additional guest.

Motel units without kitchen \$39.00 for 2 persons accommodates 4 persons, some units accommodate 6 persons.

Motel units with kitchen \$44.00 for 2 persons accommodates 4 persons, some units accommodate 6 persons.

Sleeper units without kitchen \$25.95 for 2 persons.

Sleeper cottages without kitchen \$28.00 for 2 persons, accommodates 3 persons.

Sleeper cottages with kitchen \$33.00 for 2 persons, accommodates 3 persons.

Apartments with kitchen \$45.00 for 4 persons accommodates 4-6 persons.

Efficiency apartments with kitchen \$33.00 for 2 persons, accommodates 2 persons.

Cottages with kitchen \$46.00 for 2 persons, accommodates 4-6 persons.

Sleeper cottages with kitchen \$45.00 for 4 persons, accommodates 4-6 persons.

Large 2 and 3 bedroom cottages with kitchen \$65.00, \$68.00, and \$70.00 for 6 persons, accommodates up to 10 persons.

Mobile homes 2 bedrooms \$59.00 for 4 persons, accommodates 6 persons.

Large 2 bedroom mobile home with large deck \$70.00 for 6 persons, accommodates 6 persons.

Large 3 bedroom mobile home with large deck \$80.00 for 6 persons, accommodates 8 persons.

Luxury 3 bedroom mobile home with large deck overlooking the lake \$96.00 for 4 persons, accommodates 8 persons.

One day's deposit is required on all advance reservations. Deposits are not returnable unless reservations are cancelled 10 days prior to date of reservation.

Advance reservations are expected to pay for the number of days reserved unless the office is notified in advance.

There is no charge for children two years or younger. Cribs are available.

Pets are allowed—there will be a \$5.00 per day charge for pets.

Check-in time is 2:00 p.m. on day of arrival.

Check-out time is 11:00 a.m. on day of departure.

Our area is dry, beer and liquor cannot be purchased locally, you will want to plan accordingly.



1990 Camping Rates - Dally

Based on 2 people per unit and site - each site occupied by one camping unit and one extra vehicle. All extra vehicles, boats and trailers must be parked in parking area by the office.

Water & Electric	\$14.50
Full Hook-up W/Sewer	\$16.00
Additional Person	\$ 1.00
2 years and under	FREE
Tenters - in tent area	\$ 9.00
*Day Visitors	\$ 2.00
Boat Launch area - If we launch your boat	\$ 8.00
Please check with office for time	

NEW FOR 1990

Deluxe Mobile Home and New Park Model Rentals
DELUXE MOBILE HOME includes 3 Bedrooms - Sleeps Up to 8 Central Heat & A.C • Electric Stove • Full Size Refrigerator • Microwave • Toaster • Mr. Coffee • Table Service • Pots & Pans • Dishwasher • Cable TV • Linen Service

PARK MODELS includes: 1 & 2 Bedrooms - 1 BDR Sleeps 4, 2 BDR Sleeps 6 Central Heat & A/C • Gas Stove • Full Size Refrig • Microwave • Toaster • Mr. Coffee • Table Service • Pots & Pans • Cable TV • Linen Service

RATES

3 Day Min. - Spring & Fall	Full Week Only - In Season 5/26 - 9/8 (No Refunds) (Also Offered Anytime)
Deluxe Mobile Home \$70.00 for 4 - \$5.00 ea. add'l person	Week - Sat. to Sat. - \$460.00 for 4
Park Models \$50.00 for 2 - \$5.00 ea. add'l. per	(\$5.00 ea. add'l. pers. per day) Week - Sat. to Sat. - \$325.00 for 2

Rates Subject to 7% tax

Check-in time 2:00 p.m. - Check-out time 10:00 a.m.

Fall Rates Available After Labor Day

NO PETS IN COTTAGES

Deposit Requested 1 day's deposit - Checks accepted if received 30 days prior to arrival. Will accept Master & Visa cards or Money Orders if less than 30 days. Refund only if notified 30 days prior to reservation. within 30 days - only if we re-book \$1.50 charge for postage and handling on refunds.

**TOLL FREE NUMBER
FOR RESERVATIONS ONLY
CAMPGROUND, COTTAGES
& MARINA**

1-800-326-3625

Monthly and seasonal rates available — we welcome your inquiries. 3 day minimum on all Holiday Weekends.

*All visitors to your campsite must stop and register at the office and pay visitor fee of \$2.00 and be issued a pass. Visitor is entitled to use of the pool and all other facilities and must observe the same rules as camper.

Deposit requested — \$15.00 per site. Deposit will be refunded only if notified within 7 days of reservation and there will be a \$1.50 charge for postage and handling on refund. *Exception - Triple AAA members.

Checkout Time is 2:00 p.m. on all sites. PLEASE ADVISE BY 10:00 a.m., if you wish to stay longer, otherwise there will be a late charge of \$3.00 per hour.

Please do not run generators on the campground.

Your pets are welcome but must be on a leash. (This rule applies to campers only - NO PETS allowed in cottages.)

Church services of most denominations are within a short distance of campground. Please check at office for times and locations.

Relax — Enjoy your vacation. Everything you need is right here. Our quiet relaxed campground atmosphere and friendly folks will make you want to stay forever. Enjoy fishing, water skiing and the beautiful Kentucky Lake shoreline while boating.

CAMPERS & COTTAGE GUESTS SLIP RENT SPECIAL
 Pay in advance upon registration at campground, present paid receipt to marina office and receive 50¢ per night discount off of slip rent. (1 per campsite or cottage.)

To write or call us direct for
Information,
please contact as follows:

**Sportsman's
Campground:**

502/354-8493
Rt. #5, Box 401
Benton, KY 42025

Sportsman's MARINA

For Reservations Only - Call Free Throughout U.S.

1-800-326-3625

Sportsman's Marina

Bait, Tackle - Everything for the Fisherman and Boater • Gas, Ice, Coffee, Sandwiches, Soft Drinks, Snacks and Souvenirs • 200 Covered Boat Slips - Accommodations for Small Fishing Boats up to Large Houseboats • Free Boat Launching Ramp • Pontoon, 14' Fishing Boats, Fully Rigged Bass Boats and Houseboats for Rent • Experienced Guide Service - For Crappie, Bass, Sauger and Stripers - Fishing License

1990 RENTAL RATES
 *Covered Slips - \$7.00 a night up to 21' (22' plus additional charge)

3 day minimum on Holiday Weekends.

*Monthly, seasonal and yearly rates also available, we welcome inquiries Slips are also available for cruisers and houseboats up to 52 feet. Rates quoted upon request.

14' Fishing Boats — \$15.00 a day

14' Fishing Boats with Motor — \$30.00 a day (plus gas) \$22.00 half day (plus gas)

\$10.00 an hr. (plus gas) — Capacity 4

**Bass Boats — fully rigged — All Rental Boats Plus

16' Duracraft w/35 HP Evinrude 5% KY Sales Tax

\$75.00 a day (plus gas)

\$50.00 half day (plus gas)

Capacity 3

**17' Duracraft w/50 HP Evinrude

Traveler's Checks only.

\$85.00 a day (plus gas)

\$60.00 half day (plus gas) — Capacity 4

Bass boats equipped with depth finder, trolling motor and battery. Our fishing boats are all under cover with locker and electric provided for your convenience.

NEW Wave-Runners — \$40.00 an hour

(\$50.00 damage deposit requested)

**Pontoon Boats — \$125.00 a day (plus gas)

(PM only) \$85.00 half day (plus gas)

(PM only) \$35.00 an hour (plus gas)

**No Pets allowed on board

DEPOSIT REQUIREMENTS:

Boat slips (please give length & width of boat) .. \$ 7.00

14' fishing boat without motor \$15.00

14' fishing boat with 9.9 HP Evinrude motor \$30.00

*Pontoon Boats — 16' and 17' Bass Boats \$50.00

*Deposit will also be held during rental period as damage

deposit on Bass Boats & Pontoons.

Deposits will be refunded if notified within 7 days of

reservation and there will be a \$1.50 charge for postage

and handling on refund. *Exception - Triple AAA

members. Be sure to notify marina directly.

To write or call us direct for

Information,

please contact as follows:

**Sportsman's
Marina:**

502/354-6568
 Rt. #5, Box 402
 Benton, KY 42025

SPORT FISHING LICENSES AND FEES (301 KAR 3:021, KRS 150.225)

Type of License	Res.	Non res.
Annual fishing	8.50	20.00
Combination hunting and fishing	15.00	NA
Joint husband/wife fishing	15.30	NA
3-day fishing	NA	7.50
15-day fishing	NA	12.50

KY CREEL AND SIZE LIMITS

SPECIES	DAILY LIMIT	POSSESSION	SIZE
BLACK BASS	10	20	*14/1
ROCK BASS	15	30	none
SAUGER	10	20	none
WHITE BASS	60	60	none
CRAPPIE	60	60	none

*14/1-No more than one bass under 14 in.

BOAT REQUIREMENT

1. Kill Switch
2. Life Jackets
3. Fire Extinguisher
4. Horn or Whistle
5. Safety Cushions
6. First Aid
7. State Fishing License

National Bass Association of the Deaf

SCHEDULE of EVENTS 1991

June 9, Sunday

- 8 A.M. NBAD Executive Board Meeting
- 1 P.M. to 5 P.M. NBAD Registration
- 7 P.M. Council of Representative Meeting

June 10, Monday

- 5 A.M. to 11 A.M. Bass Lunker Contest
- 8 A.M. to 11 A.M. NBAD Registration
- 1 P.M. General Assembly
Election of Officers
Bidding for Tournament Sites
Presentation of NBAD Patches to
Rookies
- 6 P.M. to 8 P.M. JR NBAD's Fishing Derby

June 11, Tuesday

- 5 A.M. to 3 P.M. Team Tournament
- 10 A.M. Family Recreation- Maggie's Jungle
Golf
- 3 P.M. Weigh-in
- 7 P.M. Announcement of the Winners
1-2-3 Places and Lunker
Social

June 12, Wednesday

- 5 A.M. to 3 P.M. Team Tournament
- 10 A.M. Family Recreation- New Wonder Water
- 3 P.M. Weigh-in
- 7 P.M. Announcement of the Winners
1-2-3 Places and Lunker
Door Prizes

June 13, Thursday

- 5 A.M. to 3 P.M. Team Tournament
- 1 P.M. Family Recreation- Forgotten Past
Amusement Park
- 3 P.M. Weigh-in
- 7 P.M. Announcement of the Winners
1-2-3 Places and Lunker
Announcement of Team Champions,
Sportsmanship and Bassmaster

CAMPGROUND

RESORTS — HOTELS — MOTELS — COTTAGES

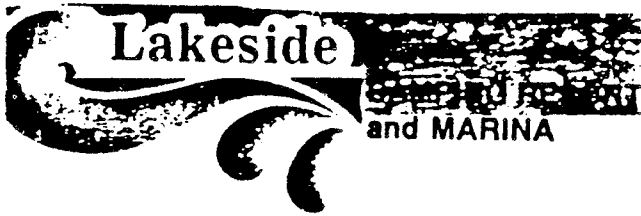

Location — U.S. Highway 68 at Jonathan Creek on Kentucky Lake

(502) 354-8157



Cedar Lane Resort

Motel & Campground

Swimming Pool — Nature Trails — Games

Route 1
Hwy. 68
Aurora, KY 42048

For RESERVATIONS
CALL Linda or Ron
(502) 474-8042



LARGE POOL - COLOR TV - MOTEL
AIR CONDITIONING - KITCHENETTES
AND MOBILE HOMES
SR. CITIZENS DISCOUNT
KIDS UNDER 16 FREE

Early American Motel

ON HIGHWAY 68 IN AURORA, KY
WEST OF KENLAKE STATE PARK

HOSTS

CHUCK & JEANETTE KLAPROTH

TELEPHONE
502-474-2241

ROUTE 1
AURORA, KY 42048



Hunting & Fishing

Hunting
and
Fishing
Headquarters
for
Kentucky
and
Barkley Lakes

Route 1 * Aurora, Kentucky 42048 * (502) 474-2351

R.R. 1, Box 514
Aurora, KY 42048

Telephone
502-474-2288



RESORT
MOTEL

at Beautiful Kentucky Lake
Your Hosts

HARVEY & PATRICIA (PAT) PICKARD

Lakewood Campground

Rt 5 Benton

Ronnie and Shirley Blakely

Open all year

(502) 354-8619

Town & Country Resort

Rt 5 Box 370 Benton

(502) 354-6587

Located off hwy 68 and on the
shores of Jonathan Creek.

For more information — Write or phone:
LAKELAND RESORT
Route 1, Box 480 — Hardin, Kentucky 42048
(502) 474-2292

MONDAY
BASS FEE
\$10.00

MONDAY
BASS FEE
\$10.00

MONDAY
(From 5:00 to 11:00 a.m.)

\$1,000

BASS LUNKER CONTEST

(Based on 100 entries)

1 - \$400	4 - \$75	7 - \$35	10 - \$20
2 - \$200	5 - \$50	8 - \$30	11 - \$15
3 - \$100	6 - \$40	9 - \$25	12 - \$10



“... The fun of family fishing ...”

NEAD ENTRY FEE: \$50.00 PER PERSON IN 3 DAYS

<u>Tuesday, June 11</u>	<u>Wednesday, June 12</u>	<u>Thursday, June 13</u>	<u>Final Totals</u>
1st \$100 + 2 trophies	1st \$100 + 2 trophies	1st \$100 + 2 trophies	1st \$2000 + 2 trophies
2nd \$50 + 2 trophies	2nd \$50 + 2 trophies	2nd \$50 + 2 trophies	2nd Money + 2 trophies
3rd \$25 + 2 trophies	3rd \$25 + 2 trophies	3rd \$25 + 2 trophies	3rd Money + 2 trophies
Lunker \$25 + trophies	Lunker \$25 + trophies	Lunker \$25 + trophies	Ratio 3-1 will get money

SPECIAL PRIZES

1. \$452 Plus - NBAD's Lunker Break Record of 7 lbs and 11 oz to First Person
2. \$252 Plus - NBAD's Bassmaster Break Record of 44 lbs and .04 to First Person
3. \$252 Plus - NBAD's Team Champion Break Record of 85 lbs and 14 oz to First Person
4. Prize Money - Largest Bass Lunker in 3-day tournament
5. Prize Money - Bassmaster for the total of 3 days tournament

DAYTON DEAF ANGLERS CLUB COMMITTEES

General Chairman - Phil Seim	Booster - Leonora Phillips	Trophies - Charles Goodyear
Co-Chairman - Douglas Center	Prize Project - Phil Seim	Jr. Derby - Brenda Seim
Co-Chairman- Waldo Davis, Jr.	Program Book - Leonora Phillips	Family Recreation -
Secretary - Jerry Hacker	Advertising - Douglas Center	Maudie Goodyear
Treasurer - Leonora Phillips	Inspect Boats - Raymond Randall	Weigh-In - Waldo Davis, Jr.
Interpreter - Connie Brumbaugh		

1991 NATIONAL BASS ASSOCIATION OF THE DEAF OFFICERS

<u>President</u>	<u>Vice President</u>	<u>Secretary</u>	<u>Treasurer</u>	<u>Publicity Director</u>
Alan D. Rork	Martin H. Miller	Alice Rogers	Jack Stigers	Joseph O. Broz
2011 Ashbourne Rd.	56546 Hollywood Boulevard	12167 Wellington Ave	4413 Brenda Dr.	P.O. Box 159
Anderson, In. 46011	South Bend, In. 46619	Medway, Ohio 45341	Anderson, In. 46013	Onley, Va. 23418-0159
TTY 317/649-6309	TTY 219/287-3753	TTY 513/879-2011	TTY 317/ 642-5249	TTY 804/787-8937

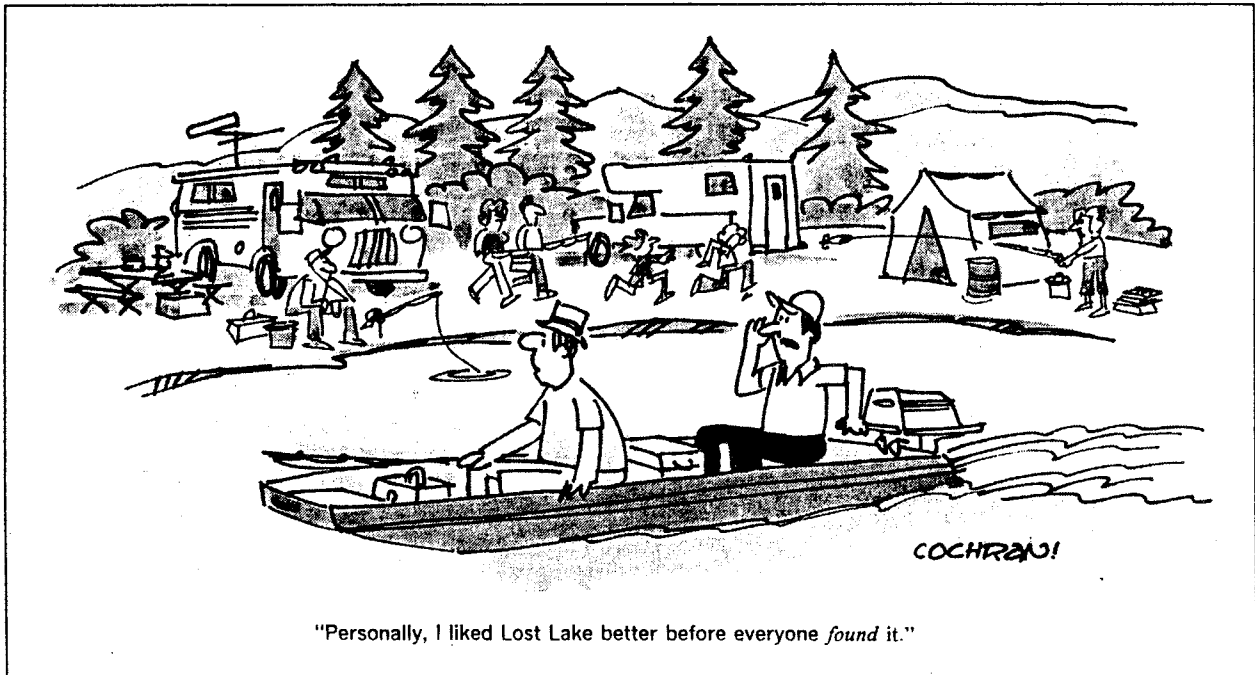

"Personally, I liked Lost Lake better before everyone found it."

SPECIAL ENTRY FEE COUPON — SAVE \$10.00

NBAD TOURNAMENT ENTRY FORM

Your Entry Fee of \$50.00 per person, payable to National Bass Association of the Deaf, is due on or before midnight, May 11, 1991. If late, it will be \$60.00! SAVE \$10.00 by sending \$50.00 per person as soon as you can to avoid the late charge. Don't mail Entry Fee after May 11, 1991 -- You must pay \$60.00 CASH per person at Kentucky Lake, Kentucky.

Mail to: National Bass Association of the Deaf
% Jack Stigers, N.B.A.D. Treasurer
4413 Brenda Drive
Anderson, IN 46013

Enclosed is: (check one)
 Money Order
 Certified Check
 Personal Check

NAME: _____

ADDRESS: _____

CITY: _____ STATE: _____ ZIP: _____

WILL YOU HAVE A PARTNER? NO YES, NAME: _____

WILL YOU BRING A BOAT? YES NO, PARTNER WILL BRING HIS BOAT.
 NO, I NEED A PARTNER WITH BOAT.

ARE YOU A MEMBER OF THE AFFILIATED CLUB? NO YES - NAME: _____

NO REFUND AFTER MAY 11, 1991